

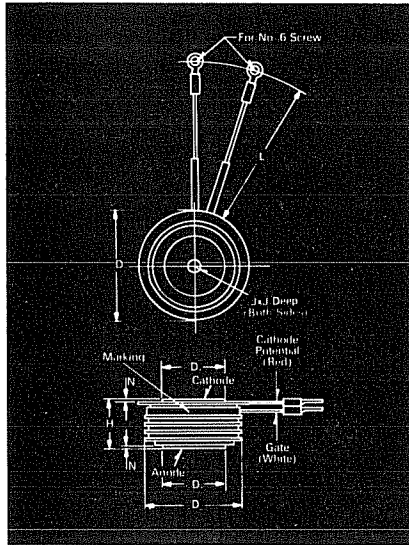

Fast Switching SCR T9GH_10

**1000A Avg.
(1570 RMS)
Up to 1200 Volts
20-60 μ s**



T9G Outline

Features:

- Interdigitated, di/namic Gate Structure
- Hard Commutation Turn-Off
- Forward Blocking Capabilities to 1200
- Low Switching Losses at High Frequency
- Soft Commutation (Feedback Diode) Testing Available
- High di/dt with soft gate control

Symbol	Inches		Millimeters	
	Min.	Max.	Min.	Max.
ϕ D	2.850	2.900	72.39	73.66
ϕ D ₁	1.845	1.855	46.86	47.12
ϕ D ₂	2.560	2.640	65.02	67.06
H	1.030	1.070	26.16	27.18
ϕ J	.135	.145	3.43	3.68
J ₁	.075	.090	1.91	2.29
L	11.50	12.50	292.10	317.50
N	.050		1.27	

Creep Distance—1.20 in. min. (30.48 mm).
Strike Distance—.70 in. min. (17.78 mm).
(In accordance with NEMA standards.)
Finish—Nickel Plate.
Approx. Weight—2 lb. (908 g).
1. Dimension "H" is a clamped dimension.

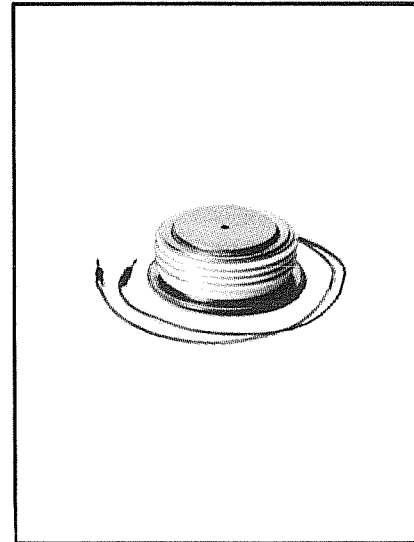

Applications:

- Induction Heating
- Transportation
- Inverters

Ordering Information

Type	Voltage		Current		Turn-off		Gate current		Leads		
Code	VDRM and VRRM * (V)	Code	I _{T(av)} (A)	Code	t _q usec	Code	I _{GT} (ma)	Code	Case	Code	
T9GH	600	06	1000	10	20	6	300	2	T9G	DH	
	800	08			25						8
	1000	10			30						5
	1200	12			40						4
					50						3
					60						2

Example

Obtain optimum device performance for your application by selecting proper order code.

Type T9GH rated at 1000A average with VDRM = 1000V
t_q = 30 usec.
I_{GT} = 300 ma, and standard 12 inch leads -- order as:

*for lower voltages consult factory

Type	Voltage	Current	Turn Off	Gate Current	Leads
T 9 G H	1 0	1 0	5	2	D H

**1000A Avg.
(1570 RMS)
Up to 1200 Volts
20-60 μ s**

**Fast Switching
SCR
T9GH_10**



Voltage

Blocking State Maximums ^① ($T_J = 125^\circ\text{C}$)

Repetitive peak forward blocking voltage, V ... V_{DRM}
 Repetitive peak reverse voltage, V ... V_{RRM}
 Non-repetitive transient peak reverse voltage,
 $t \leq 5.0$ msec, V ... V_{RSM}
 Forward leakage current, mA peak ... I_{DRM}
 Reverse leakage current, mA peak ... I_{RRM}

Symbol	600	800	1000	1200
V_{DRM}	600	800	1000	1200
V_{RRM}	600	800	1000	1200
V_{RSM}	700	900	1100	1300
I_{DRM}	← 60 →			
I_{RRM}	← 60 →			

Current

Conducting State Maximums
($T_J = 125^\circ\text{C}$)

Symbol	T9GH_10
RMS forward current, A ... $I_T(\text{rms})$	1570
Ave. forward current, A ... $I_T(\text{av})$	1000
One-half cycle surge current ^② , A ... I_{TSM}	15,000
I^2t for fusing ($t=8.3$ ms) A^2sec ... I^2t	937,000
Max I^2t of package ($t=8.3$ ms), A^2sec ... I^2t	90×10^6
Forward voltage drop at $I_T = 1500\text{A}$ and $T_J = 25^\circ\text{C}$, V ... V_{TM}	2.10
Min. Repetitive di/dt A/usec. ^③ ^④ ^⑤ di/dt	500

Gate

($T_J = 25^\circ\text{C}$)

Symbol	Min	Typ	Max
Gate current to trigger at $V_D = 12\text{V}$, mA ... I_{GT}		200	300
Gate voltage to trigger at $V_D = 12\text{V}$, V ... V_{GT}		1.5	3.0
Non-triggering gate voltage, $T_J = 125^\circ\text{C}$, and rated V_{DRM} , V ... V_{GDM}			.15
Non-triggering Gate Current at $V_D = 12\text{V}$, mA ... I_{GNT}		20	
Peak forward gate current, A ... I_{GTM}			10
Peak reverse gate voltage, V ... V_{GRM}			5
Peak gate power, Watts ... P_{GM}			60
Average gate power, Watts ... $P_{G(av)}$			3

Switching

($T_J = 25^\circ\text{C}$)

HARD COMMUTATION: ^①

Typical Turn-off time, $I_T = 1000\text{A}$

$50\text{V} \leq V_R \leq V_{RRM}$

$T_J = 125^\circ\text{C}$, $di/dt = 100\text{A}/\mu\text{sec}$
reapplied $dv/dt =$

200V/ μsec linear to 0.8 V_{DRM} , μsec

Typical Turn-On and Delay Time

$I_T = 1000\text{A}$, $t_p = 450 \mu\text{sec}$

$V_D = 1100\text{V}$, μsec

Typical Reverse recovery charge for 40
 μsec device.

$I_T = 1000\text{A}$, $di/dt = 100\text{A}/\mu\text{sec}$

$T_J = 125^\circ\text{C}$, $t_p = 100 \mu\text{sec}$, μC

Minimum Critical dv/dt exponential
to V_{DRM}

$T_J = 125^\circ\text{C}$, V/ μsec ^② ^③

Minimum di/dt @ non-repetitive,

^④ ^⑤ A/ μsec

Latching Current

$V_D = 75\text{V}$, mA

Holding Current

$V_D = 75\text{V}$, ma

Thermal and Mechanical

Symbol	Min	Typ	Max
Oper. junction temp., $^\circ\text{C}$... T_J	-40		125
Storage temp., $^\circ\text{C}$... T_{stg}	-40		150
Mounting force, lb ...	5000		5500
Thermal resistance with double sided cooling ^⑥			
Junction to case, $^\circ\text{C}/\text{Watt}$... $R_{\theta JC}$.023
Case to sink, lubricated, $^\circ\text{C}/\text{Watt}$... $R_{\theta CS}$.006		.0075

- ① Consult recommended mounting procedures.
- ② Applies for zero or negative gate bias.
- ③ Per JEDEC RS-397, 5.2.2.1.
- ④ With recommended gate drive.
- ⑤ For different turn-off values or conditions, consult factory.
- ⑥ Per JEDEC standard RS-397, 5.2.2.6.
- ⑦ For operation with antiparallel diode, consult factory.

Maximum Forward Voltage Drop Vs. forward Current

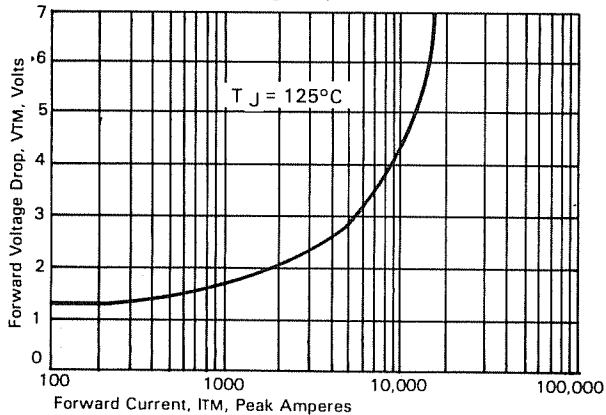

Transient Thermal Impedance VS. Time

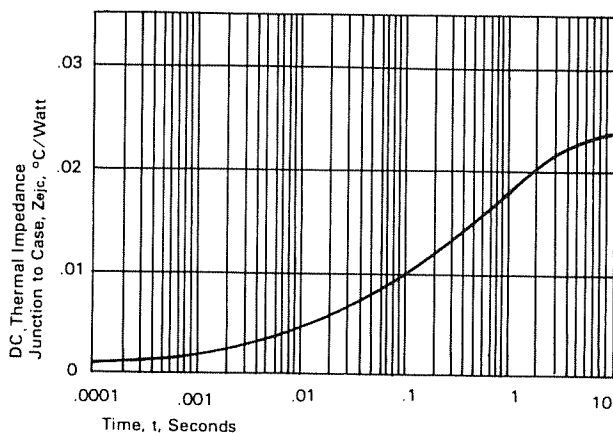



Fast Switching SCR T9GH_10

1000A Avg.
(1570 RMS)
Up to 1200 Volts
20-60 μ s

Sinusoidal Current Data

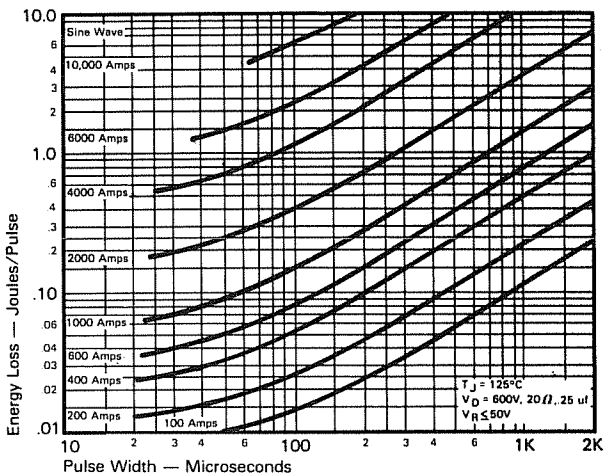

ENERGY PER PULSE FOR SINUSOIDAL PULSES

Trapezoidal Wave Current Data

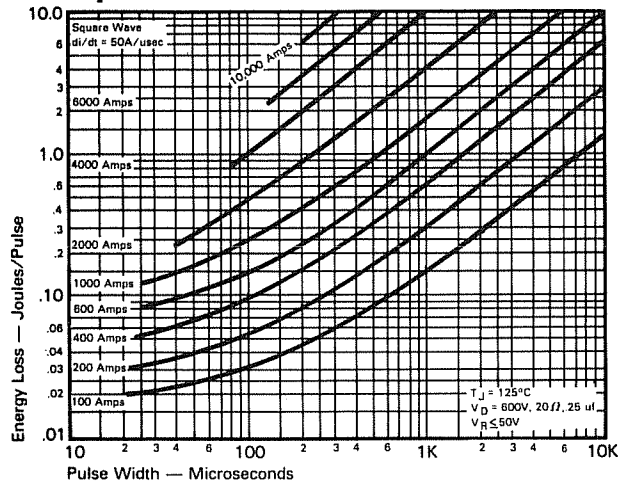

ENERGY PER PULSE FOR TRAPEZOIDAL PULSES
($di/dt = 50A/usec$)

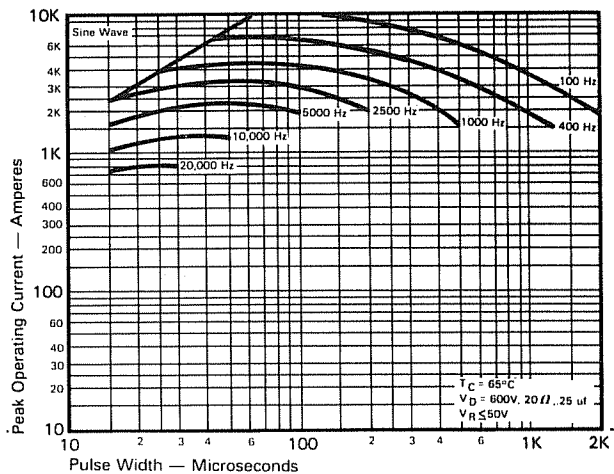

MAXIMUM ALLOWABLE PEAK ON-STATE CURRENT
vs. PULSE WIDTH ($T_C = 65^\circ C$)

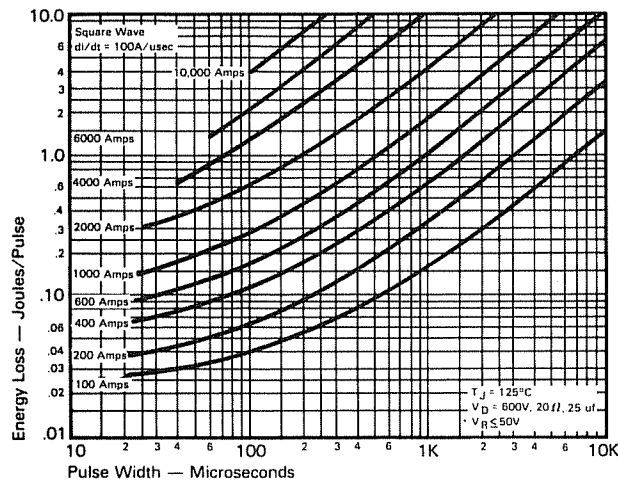

ENERGY PER PULSE FOR TRAPEZOIDAL PULSES
($di/dt = 100A/usec$)

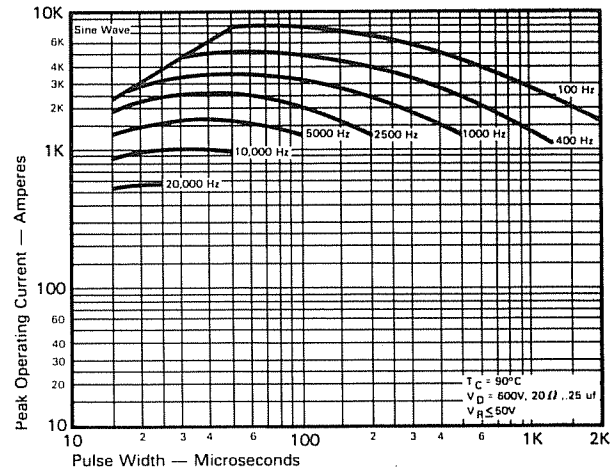

MAXIMUM ALLOWABLE PEAK ON-STATE CURRENT
vs. PULSE WIDTH ($T_C = 90^\circ C$)

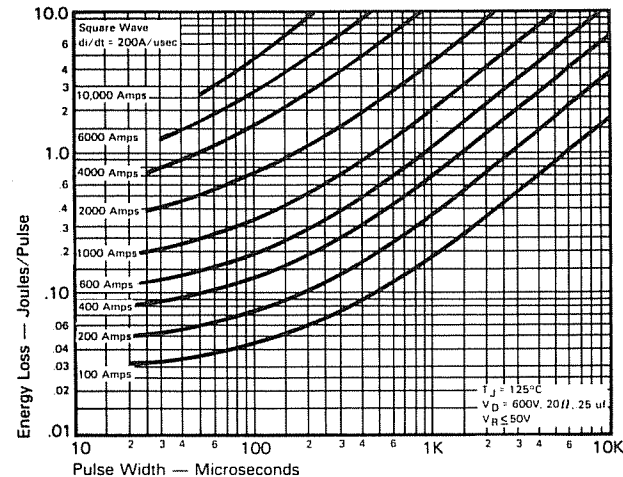

ENERGY PER PULSE FOR TRAPEZOIDAL PULSES
($di/dt = 200A/usec$)

FAST SWITCHING
THYRISTORS

1000A Avg.
(1570 RMS)
Up to 1200 Volts
20-60 μ s

Fast Switching
SCR
T9GH_10



Trapezoidal Wave Current Data
($T_C = 65^\circ\text{C}$)

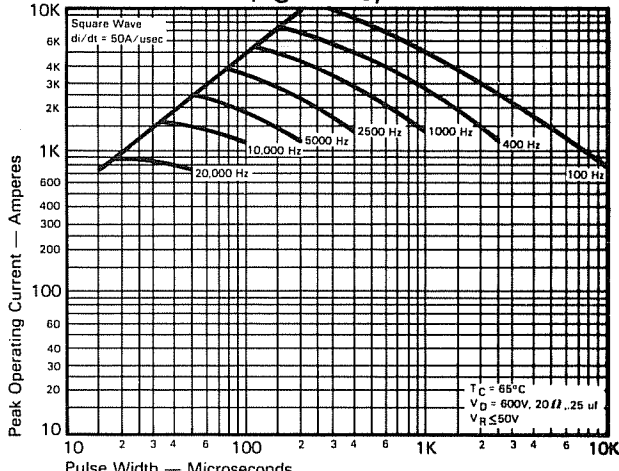

MAXIMUM ALLOWABLE PEAK ON-STATE CURRENT vs. PULSE WIDTH ($di/dt = 50\text{A/us}$)

Trapezoidal Wave Current Data
($T_C = 90^\circ\text{C}$)

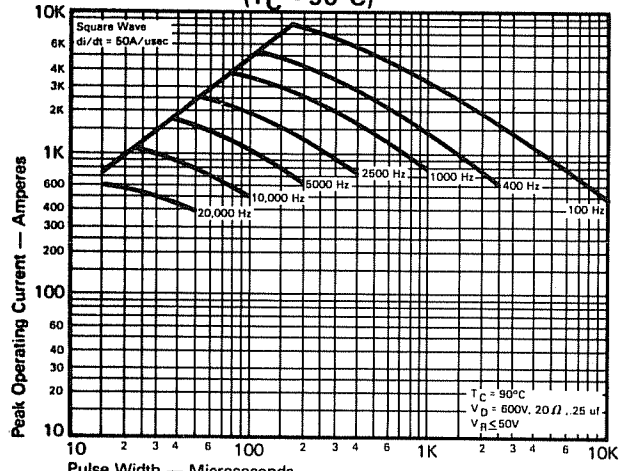

MAXIMUM ALLOWABLE PEAK ON-STATE CURRENT vs. PULSE WIDTH ($di/dt = 50\text{A/us}$)

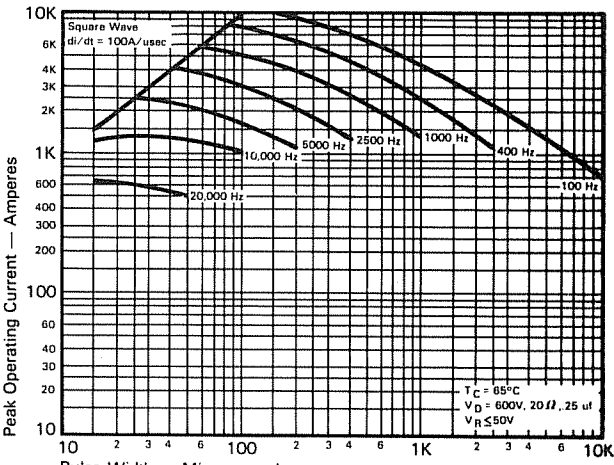

MAXIMUM ALLOWABLE PEAK ON-STATE CURRENT vs. PULSE WIDTH ($di/dt = 100\text{A/us}$)

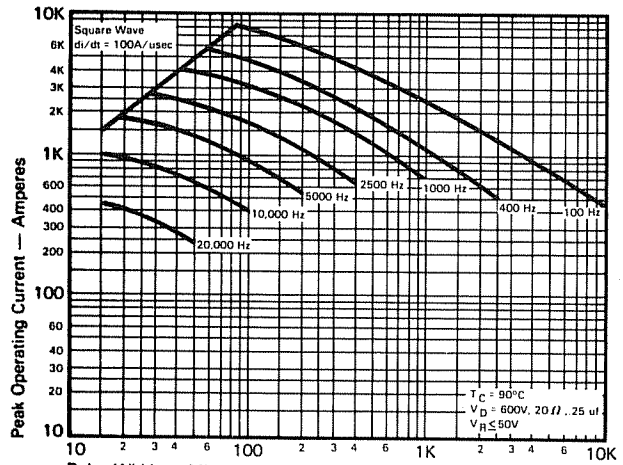

MAXIMUM ALLOWABLE PEAK ON-STATE CURRENT vs. PULSE WIDTH ($di/dt = 100\text{A/us}$)

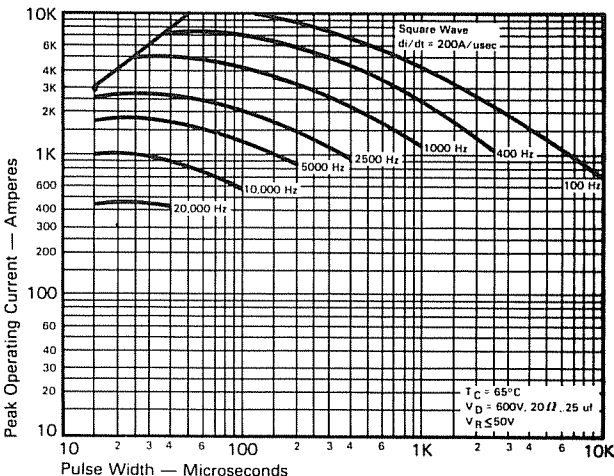

MAXIMUM ALLOWABLE PEAK ON-STATE CURRENT vs. PULSE WIDTH ($di/dt = 200\text{A/us}$)

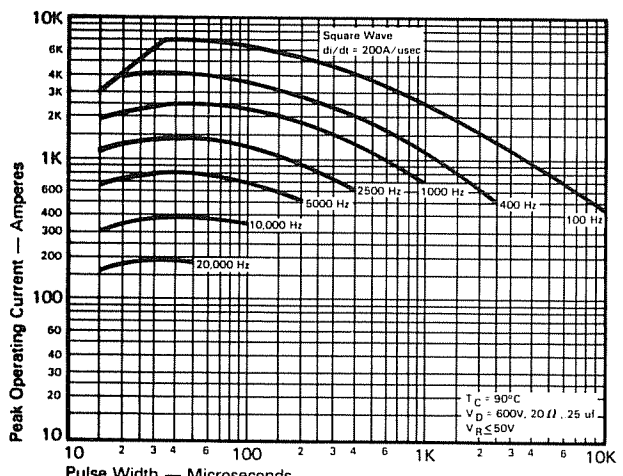

MAXIMUM ALLOWABLE PEAK ON-STATE CURRENT vs. PULSE WIDTH ($di/dt = 200\text{A/us}$)

FAST SWITCHING THYRISTORS